

2500 HN series

Single Output DC/DC Converter



DESCRIPTIONS

The 2500HN, single output power modules are 16 to 25 watt DC/DC converters available in a single output configuration providing 3.3 VDC to 15 VDC outputs in a compact, industry standard 2.0" X 1.6" X 0.4" package. These 400kHz, switching converters are available in 12, 24 and 48 VDC inputs making them one of the most versatile product lines in the market with efficiencies up to 87%. Advanced surface mount construction allows these converters to achieve outstanding thermal performance eliminating the need for thermal potting compounds and thereby enhancing manufacturing efficiency to reduce costs.

OUTPUT CHARACTERISTICS

	Min	Typ	Max	Unit/Comments
Output Voltage Set Point		±1		% Output voltage at nominal line & FL
Total Band Error	-2		+2	% Output voltage including line/load regulation setting
Line Regulation		±0.5		% Output voltage measured from min. input line to maximum
Load Regulation		±0.5		% Output voltage measured from FL to 10% load
Temperature Coefficient		±0.01		% per degree C
Ripple/Noise		60	100	mV p-p measured at 20 MHz bandwidth with ext. 1 µf cap.
Output Voltage and Current				Refer to model selection chart
Load Transient Response		±2		% Deviation of Vout voltage for a 25% load change for 200µS
Short Circuit Protection				Indefinite, Automatic Recovery
Output Voltage Trim Range		±10		% Output voltage. Place ext. resistor between pins 8 - 6 to trim down. Between pins 8 - 7 to trim up.
Overvoltage Protection		125		%; Clamp type (5VDC output set at 6.8VDC)



FEATURES

- Up to 87% Efficiency
- Single Output, 25 watt converter
- Available in 12, 24 and 48 VDC Inputs
- Industry Standard 2" X 1.6" X 0.4" Package
- Output Over Voltage, Input Over Voltage & Short Circuit Protection

INPUT CHARACTERISTICS

	Min	Typ	Max	Units/Comments
Input Voltage				
12 VDC Input Models	9	12	18	VDC
24 VDC Input Models	18	24	36	VDC
48 VDC Input Models	36	48	75	VDC
Under Voltage Shutdown				
12 VDC Input Models		8		VDC
24 VDC Input Models		17		VDC
48 VDC Input Models		33		VDC
Over Voltage Shutdown				
12 VDC Input Models		20		VDC
24 VDC Input Models		40		VDC
48 VDC Input Models		80		VDC
Full Load Input Current				
12 VDC Input Models			2.1	A
24 VDC Input Models			1.26	A
48 VDC Input Models			0.62	A
Input Fuse Requirements				
12 VDC Input Models			7	Amps; Slow blow type
24 VDC Input Models			4	Amps; Slow blow type
48 VDC Input Models			2	Amps; Slow blow type
Efficiency by Model				
2503S12HN		78		%; FL Nominal Line
2505S12HN		80		%; FL Nominal Line
2512S12HN		82		%; FL Nominal Line
2515S12HN		84		%; FL Nominal Line
2503S24HN		79		%; FL Nominal Line
2505S24HN		83		%; FL Nominal Line
2512S24HN		86		%; FL Nominal Line
2515S24HN		87		%; FL Nominal Line
2503S48HN		80		%; FL Nominal Line
2505S48HN		84		%; FL Nominal Line
2512S48HN		86		%; FL Nominal Line
2515S48HN		87		%; FL Nominal Line
Switching Frequency	360	400	440	kHz; Factory set
Remote Shut Down	Off	0	0.80	VDC; Referenced to input (-)
	On	3.5		VDC or open; Referenced to input (-)
Input - Output Capacitance			1000	pF
Input Filter				LC type
Isolation Voltage				
12 VDC & 24 VDC Input Models				
Input to Output		750		VDC
Input to Baseplate		750		VDC
Output to Baseplate		750		VDC
48 VDC Input Models				
Input to Output		1100		VDC
Input to Baseplate		1100		VDC
Output to Baseplate		750		VDC
Isolation Resistance		100		MOHms

Martek Power reserves the right to change specifications without notice.



MODEL SELECTION CHART

	Input Voltage (VDC)	Output Voltage (VDC)	Full Load Output Current (A)
2503S12HN	12	3.3	5.0
2505S12HN	12	5.0	4.0
2512S12HN	12	12.0	1.7
2515S12HN	12	15.0	1.33
2503S24HN	24	3.3	6.0
2505S24HN	24	5.0	5.0
2512S24HN	24	12.0	2.0
2515S24HN	24	15.0	1.66
2503S48HN	48	3.3	6.0
2505S48HN	48	5.0	5.0
2512S48HN	48	12.0	2.0
2515S48HN	48	15.0	1.66

GENERAL CHARACTERISTICS

	Min	Typ	Max	Unit/Comments
Operating Temp. Range	-40		+110	°C; measured at baseplate
Storage Temp. Range	-55		+125	°C; measured at baseplate
Material Flammability				UL94V-0
Altitude: Operating			10,000	Feet
Non-Operating			40,000	Feet
Relative Humidity	5		95	% Humidity, non-condensing
Weight			22	Grams
Size				2" X1.6" X0.4"
Case Material				Black coated aluminum
Agency Approvals				UL/CUL1950

OUTLINE DRAWING

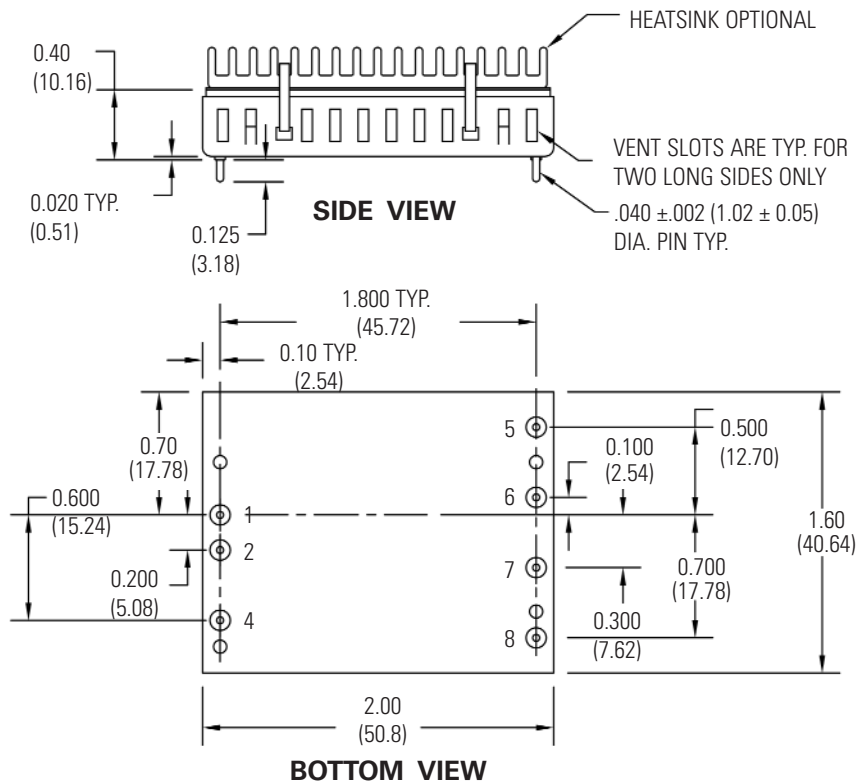

PIN OUT CHART

Pins	FUNCTION
1	+ INPUT
2	- INPUT
4	CONTROL
5	NO PIN
6	+ OUTPUT
7	- OUTPUT
8	TRIM

Notes:

1. Unless otherwise specified dimensions are in inches (mm).
2. Controlling dimension in inch.
3. Tolerances

Inches	mm
X.XX = ±0.02	X.X = ±0.5
X.XXX = ±0.010	X.XX = ±0.25

All specifications are typical at nominal input, nominal load and 25° C unless otherwise specified.
 External, low ESR, 33 microfarad (minimum) capacitor across output is recommended for operation.



How To ORDER

HOW TO ORDER

25 XX S XX HN - Y

Wattage ——— **25**

Output Voltage ——— **XX**

Single Output ——— **S**

Input Voltage ——— **XX**

ROHS Compliant ——— **HN**

Hi-Density, Non-Encap ——— **- Y**

H Options: To add external heatsink mounted on the baseplate of the converter please add a “- H” at the end of the part number. Heatsink is provided to improve thermal performance (see derating curves).

DERATING CURVES

MODEL 2500HN Single 3.3V & 5V (Without heatsink)

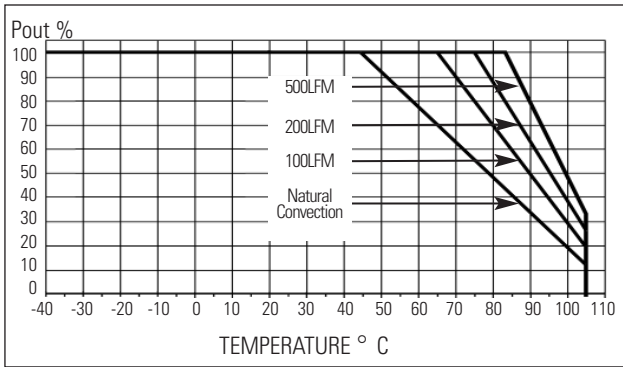

MODEL 2500HN Single 3.3V & 5V (With heatsink)

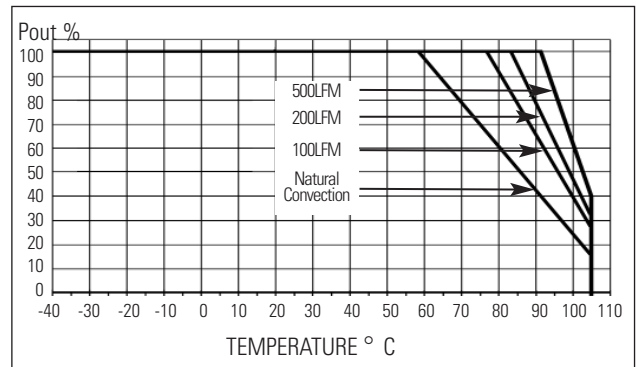

MODEL 2500HN Single 12V & 15V (Without heatsink)

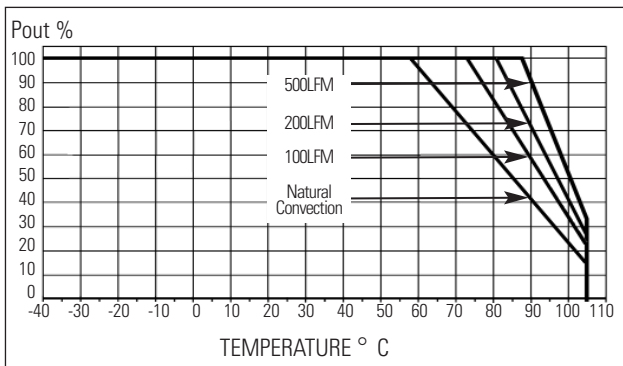

MODEL 2500HN Single 12V & 15V (With heatsink)

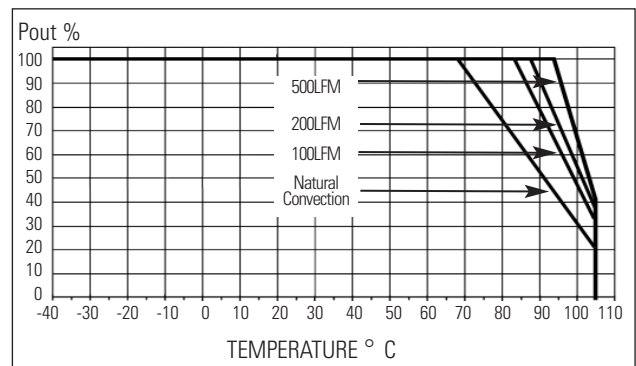



OUTPUT VOLTAGE ADJUSTMENT (2500HN SINGLE SERIES)

The converter's output voltage may be trimmed by up to ±5% of the nominal output voltage.

TRIM UP

Trim output voltage up by connecting an external resistor between Pins 7 and 8. Use the following equation, reference Table 1 for variables A and B.

$$\text{Radj-up} = \frac{A}{\Delta \%} - B \text{ (k}\Omega\text{)}$$

Example:

Trim 5% up for 12V Output units,
where A = 1.58, B = 20, Δ % = 0.05

$$\text{Radj-up} = \frac{1.58}{0.05} - 20 = 11.6 \text{ k}\Omega$$

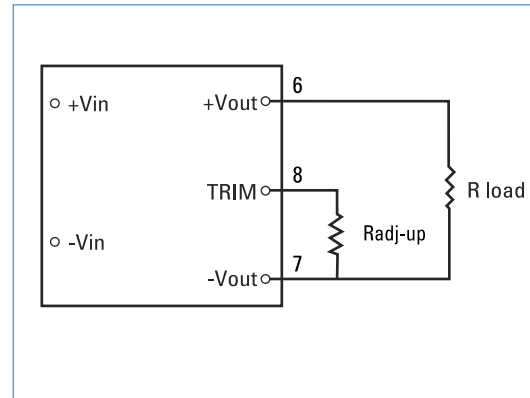

Table 1.

Output Voltage	A	B
3.3V	1.25	4.7
5V	1.00	10
12V	1.58	20
15V	1.67	20

TRIM DOWN

Trim output voltage down by connecting an external resistor between Pins 6 and 8. Use the following equation, reference Table 2 for variables C and D.

$$\text{Radj-down} = \frac{C}{\Delta \%} - D \text{ (k}\Omega\text{)}$$

Example:

Trim 5% down for 15V Output units,
where C = 8.33, D = 30, Δ % = 0.05

$$\text{Radj-down} = \frac{8.33}{0.05} - 30 = 136.6 \text{ k}\Omega$$

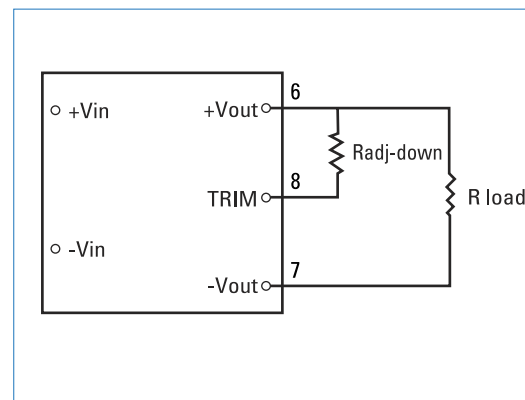

Table 2.

Output Voltage	C	D
3.3V	2.07	8.02
5V	1.00	12
12V	6.09	27.7
15V	8.33	30